

Starlase AO2

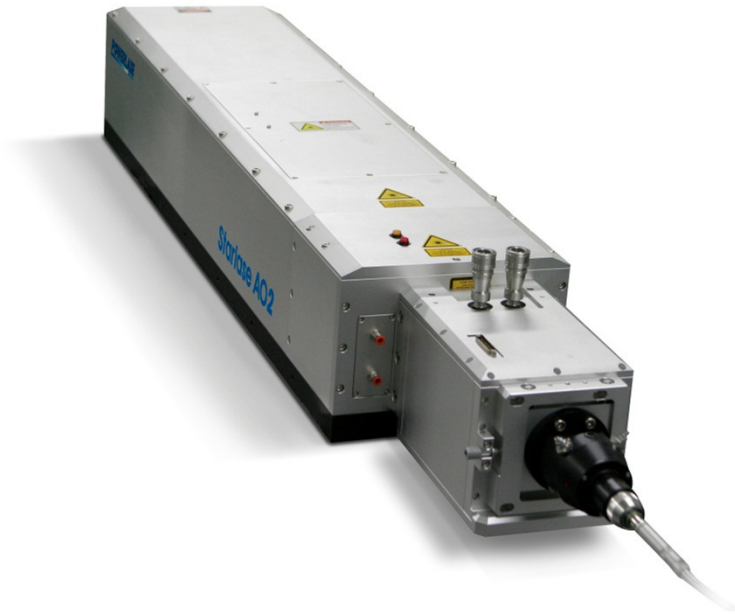

An acousto-optically Q-switched, diode-pumped Nd:YAG laser system designed for high-volume 24/7 manufacturing environments. Delivers high average powers at a wavelength of 1064 nm, unpolarised. Rugged head design and a flexible control system provide a platform that is ideally suited to industrial applications. A microprocessor architecture allows for serial interfaces, touch screen control and simple integration with OEM equipment and process lines. Real time condition-monitoring provides details of laser performance using power monitors and internal diagnostics. The laser cavity design is optimized for stable operation across a wide range of pulse repetition frequencies and first pulse control and CW leakage suppression can be provided across the performance range. Integrated optical attenuator and fibre delivery options are available to provide flexible beam delivery and output power control.

Applications

- LCD production
- Photovoltaic processing
- Silicon processing
- Bar coding

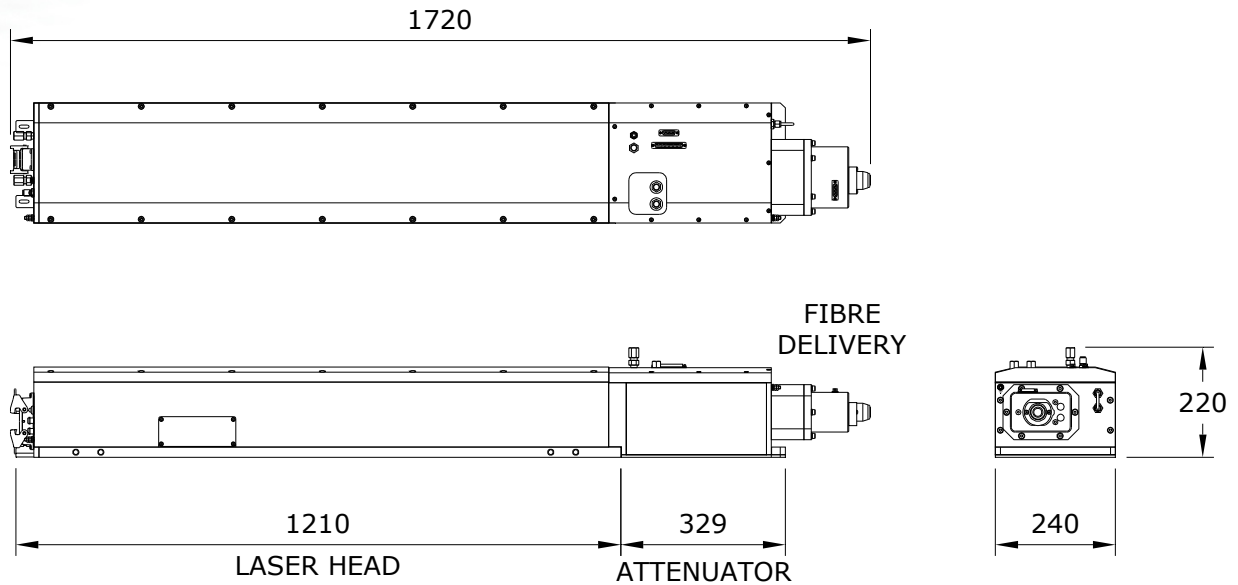

Typical laser performance

	Low PRF			High PRF		
	3	6	10	10	20	50
Pulse Repetition Freq. (kHz)	3	6	10	10	20	50
Average Power (W)	75	160	190	140	200	210
Pulse Energy (mJ)	25.0	26.6	19.0	14.0	10.0	4.2
Pulse Duration (ns)	30	45	55	45	90	160
Divergence (mrad, 1/e² FA)	12	10	8	11	11	11
M²	15 to 27					
Typical Power Stability	±1% pk-pk					

Facility requirements

Supply Voltage	400 VAC (±10%)
Supply Frequency	50/60 Hz
Nominal Power Consumption	9 kVA
Cooling Water	10 litres/min at 11-17°C
Gas Purge	N ₂ or Air (Grade N5.0, <1 ppm THC)
Laser Dimensions	1720 x 240 x 220 mm
Control Rack Dimensions	1885 x 600 x 1192 mm (h x w x d)
Environmental Conditions	Temp. 15-32°C and RH <60% (90% max, non condensing)

Specifications subject to change without notice

**LASER RADIATION
AVOID EYE OR SKIN EXPOSURE TO
DIRECT OR SCATTERED RADIATION
CLASS 4 LASER PRODUCT**